

Spindle inside contour

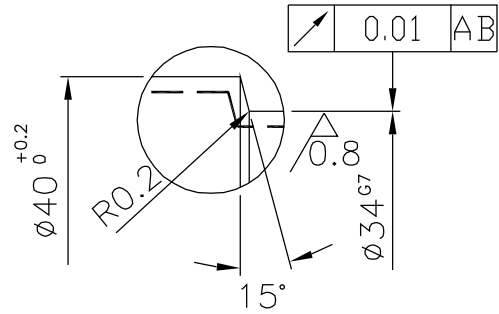
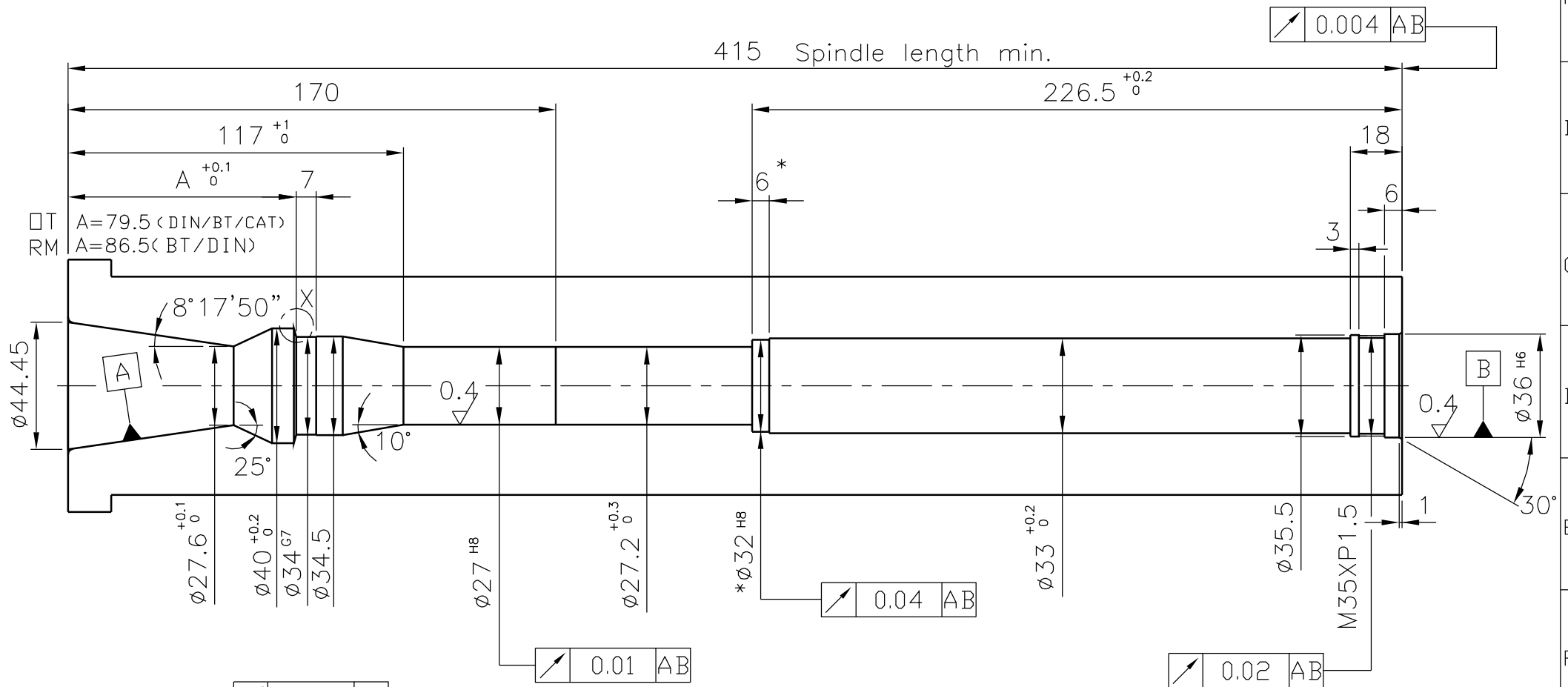

<http://smartc.company>

* to be cancelled when spindle length < 520mm 銳角去除

DETAIL X
H Rc 60±2°
Eht. min 1mm

處理	備註	材質	硬度	第三角法	比例	台件	設計	日期
40SPIND			RC		1/2		H. J.	00/6/22
			S.M.	圖號	40SPINDLE			

40PSTB/750

40PS3010

Id. no.

Com. no.

H	MAS BT	DIN 69871/69872	CAT
Opening position	99.40	93.40	83.80
Clamping position	104.20	98.20	88.60
Free position	106.90	100.90	91.30

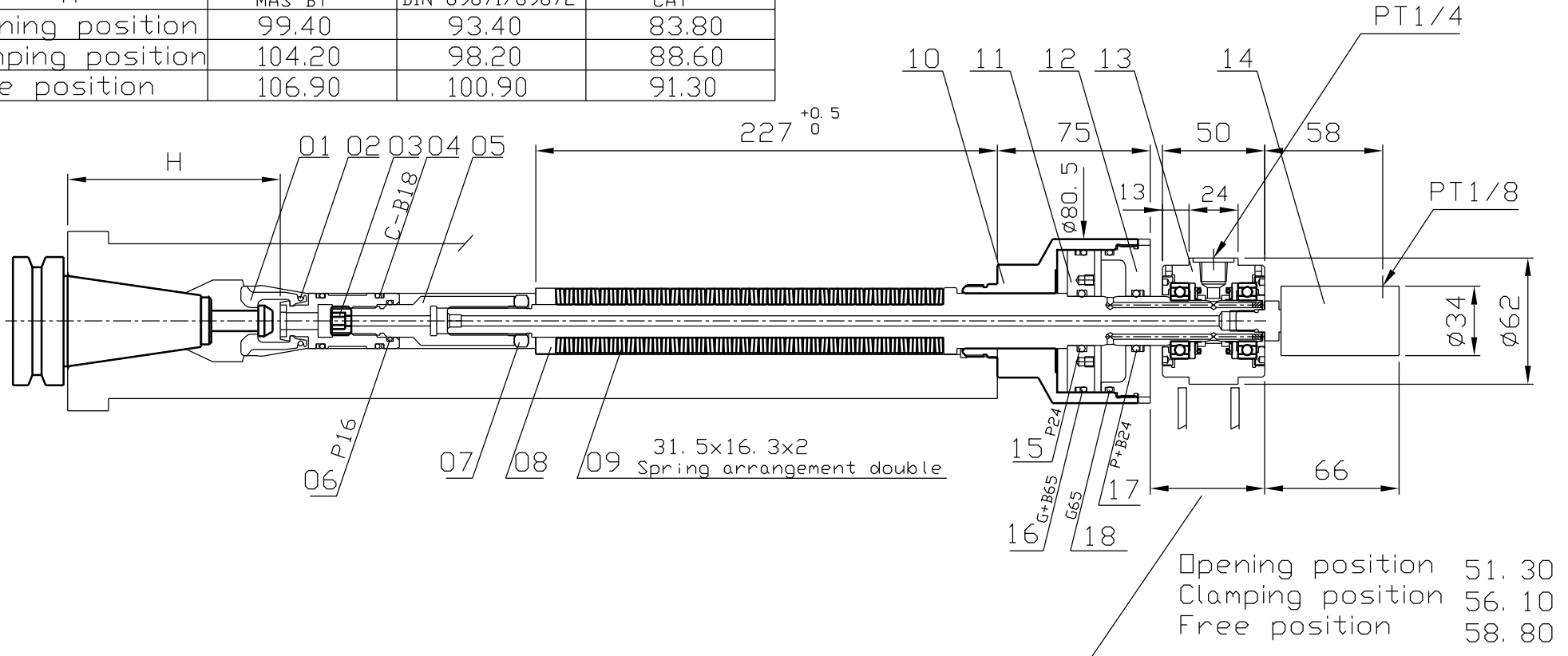

Opening position 51.30
Clamping position 56.10
Free position 58.80

Spring arrangement double
Pull force 7500N
speed 10000 rpm
opening force 50 bar (only when non-rotating)
coolant lubrication max. 80 bar
air max. 10bar
total clamping stroke 7.5mm
ejection stroke 1mm

<http://smartc.company>

PATENTED

*QUICK unclamping
clamping*

S.M.

date

00/8/25