

# Spindle inside contour

365 Spindle length min.

328 Spindle length min. (without draw bar extension)

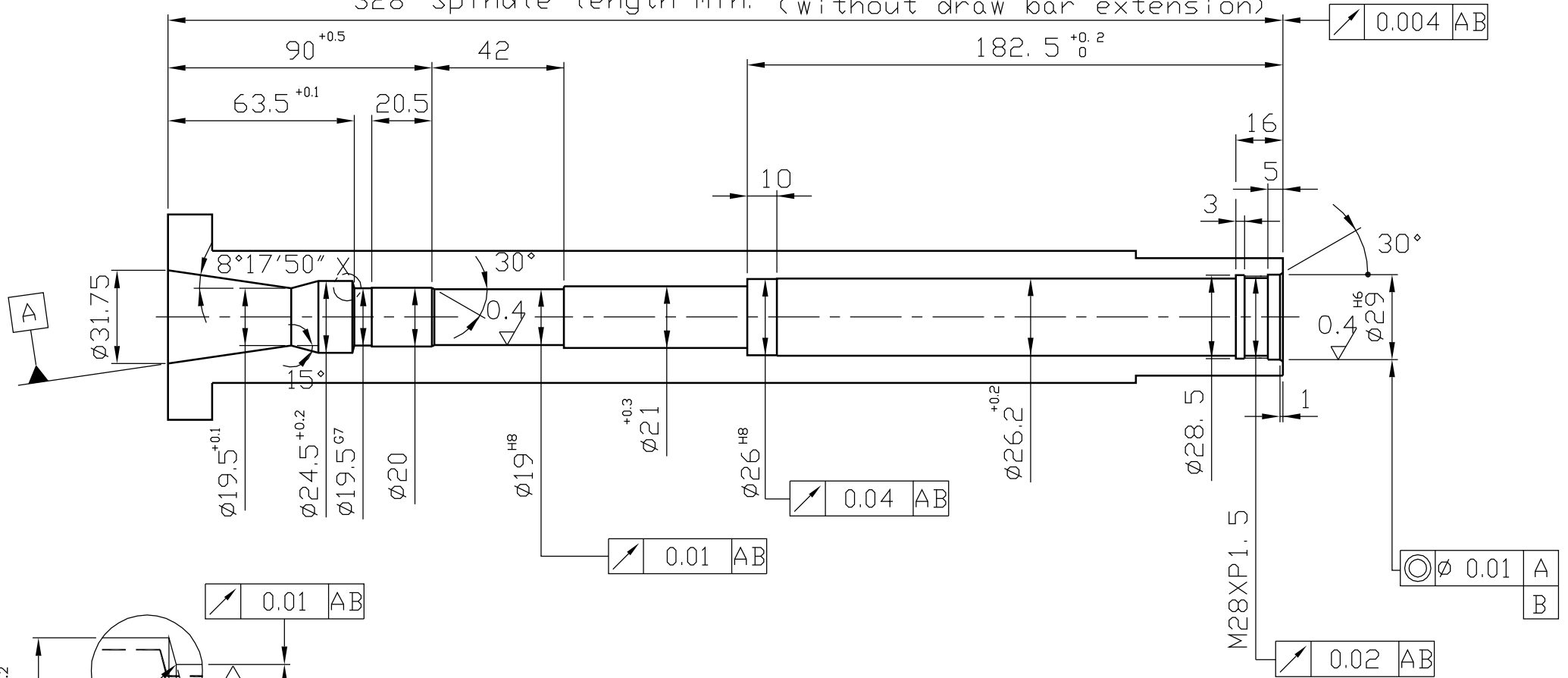

for DIN 69871/69872 SK30

ISO 7388/1/2 TYP A

JIS B 6339 BT30/30P

<http://smartc.company>

銳角去除

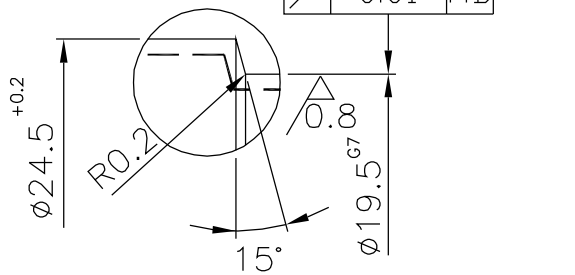

Hrc 60±2°  
Eht. min 1mm

DETAIL X

處 理	備 註	材 質	硬 度	第三角法	比 例	台 件	設 計	日 期
30SPIND3			RC		1/2	1	H.J.	05/02/08
			S.M.	圖 號	30SPINDLE			

# 30PDBS/400

30PS401

Id. Nr.

Com. Nr.

Opening position H= 70.96  
 Clamping position H= 74.96  
 Free position H= 76.66

Opening position 18  
 Clamping position 22  
 Free position 23.7

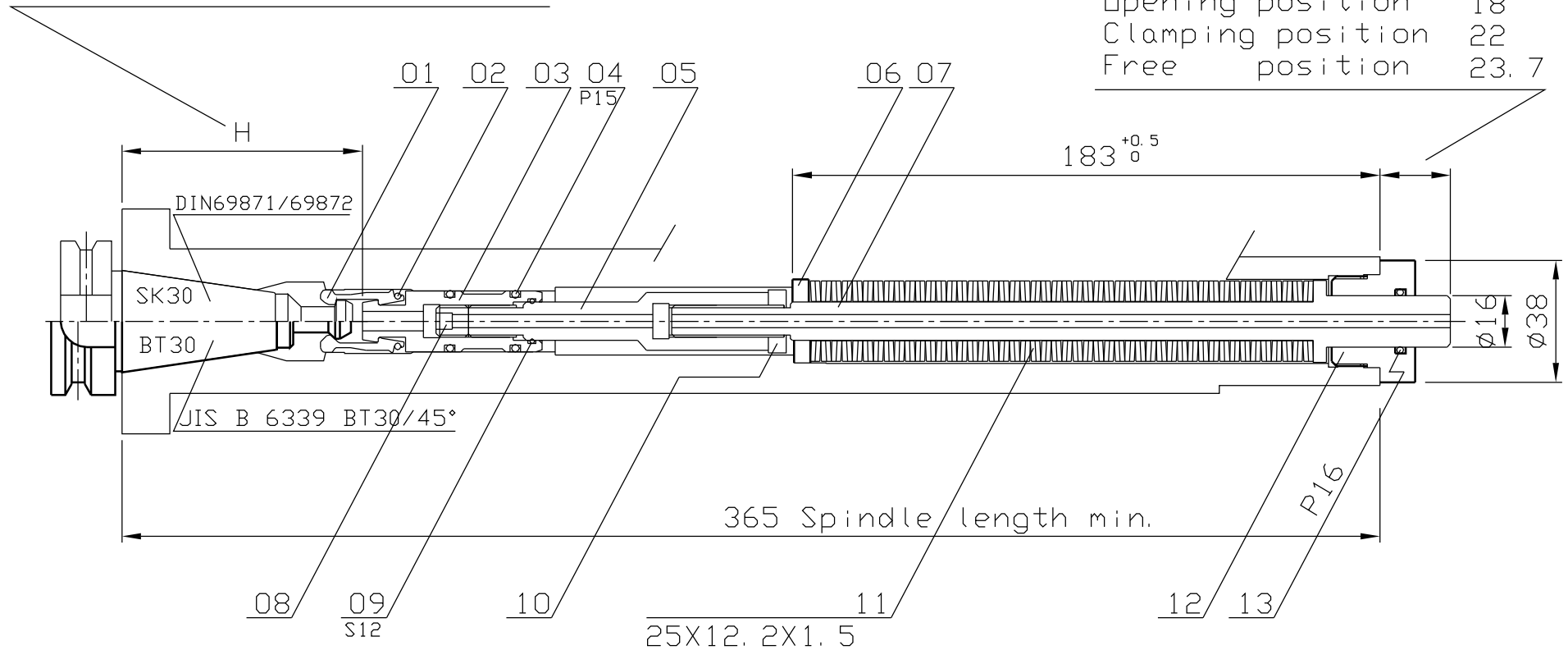

<http://smartc.company>

spring arrangement double  
 pull-in force 3100 N ±10%  
 opening force 5158 N  
 total clamping stroke 5.7 mm  
 ejection stroke 0.83 mm

S.M.

date

02/11/27