

Spindle inside contour

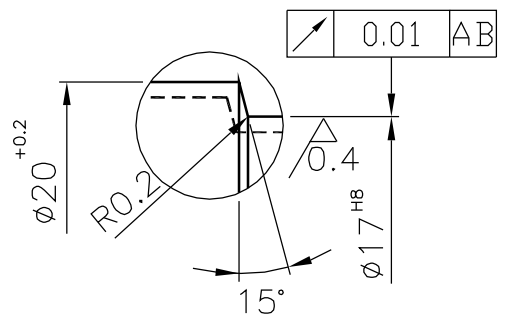
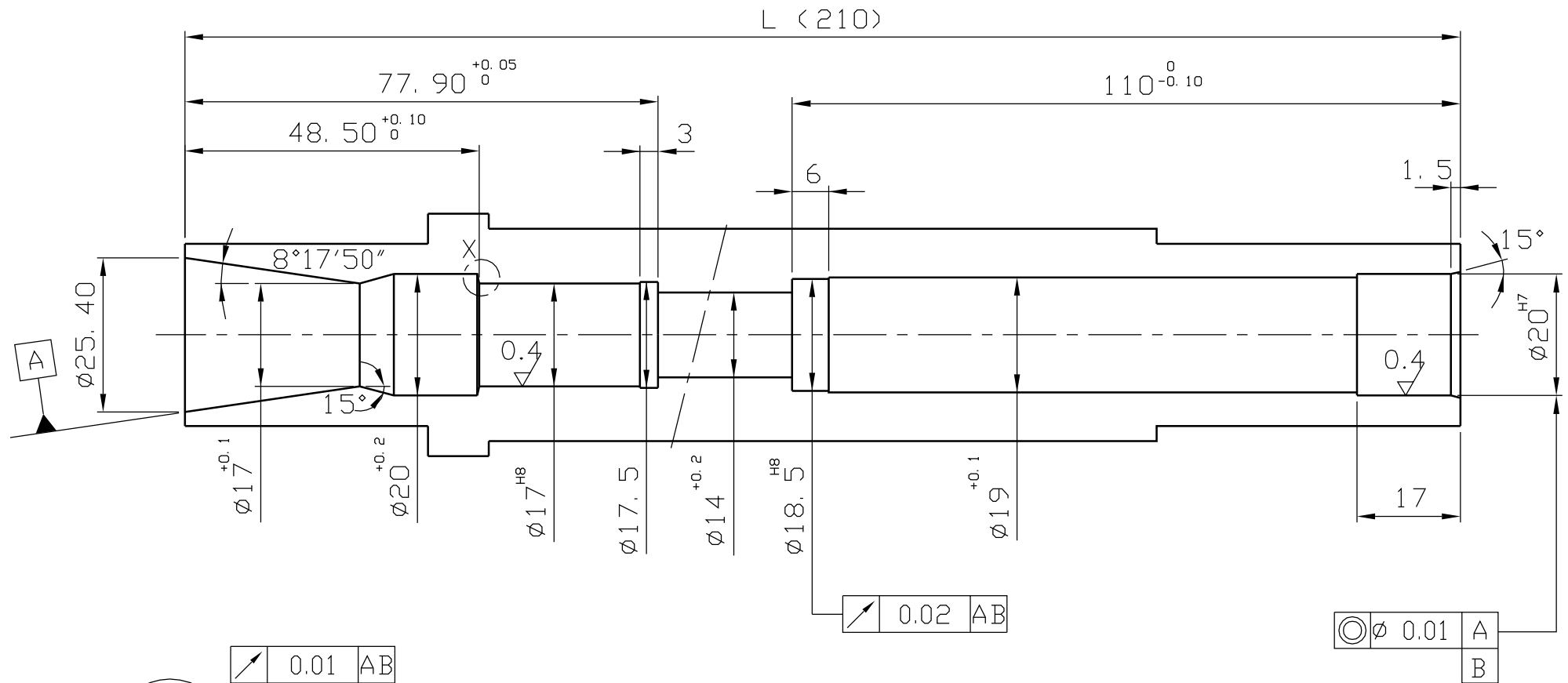

<http://smartc.company>

ISO25

銳角去除

HRC $60 \pm 2^\circ$
Eht. min 1mm

處 理	備 註	材 質	硬 度	第三角法	比 例	台 件	設 計	日 期
	25 SPIND2		RC		1/1	1	H. J.	06/01/03
<i>S.M.</i>				圖 號	25SPINDLE			

25PDBS/180

25PS182

Id. Nr.

Com. Nr.

Opening position H=55.13
 Clamping position H=58.43
 Free position H=59.93

Opening position 7.7
 Clamping position 11
 Free position 12.5

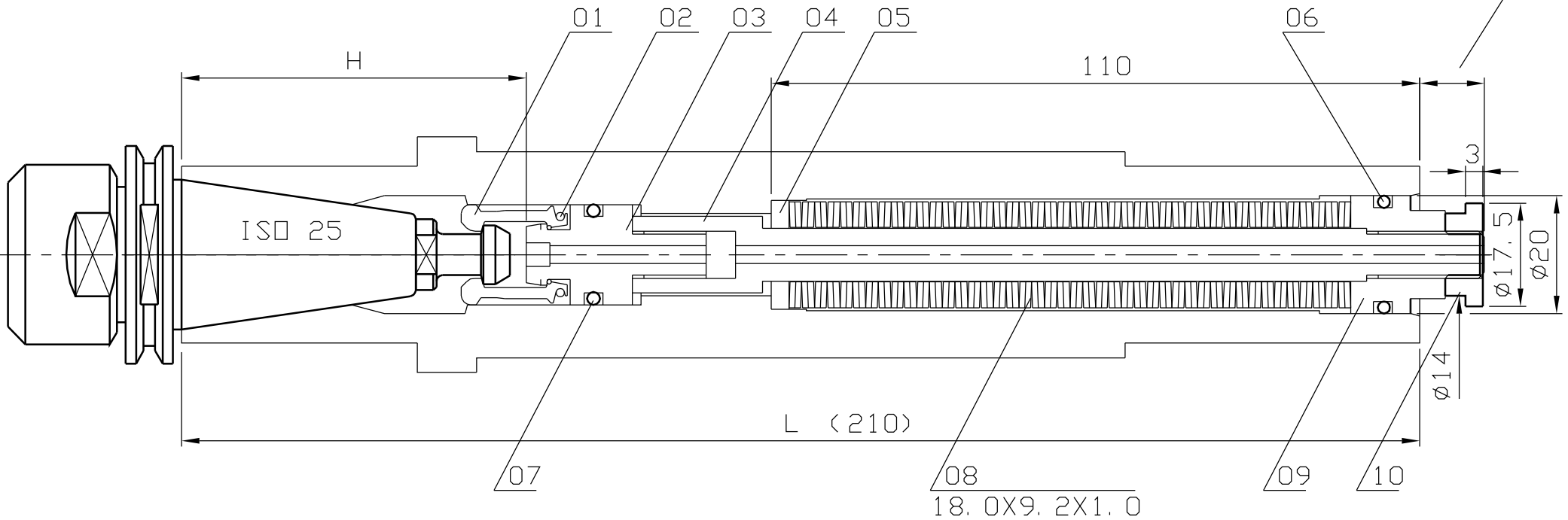

<http://smartc.company>

spring arrangement double
 pull-in force 1600 N $\pm 10\%$
 opening force 2584 N
 total clamping stroke 4.8 mm
 ejection stroke 0.5 mm

S.M.

date

08/04/28