

Spindle inside contour

L (155 spindle length min.)

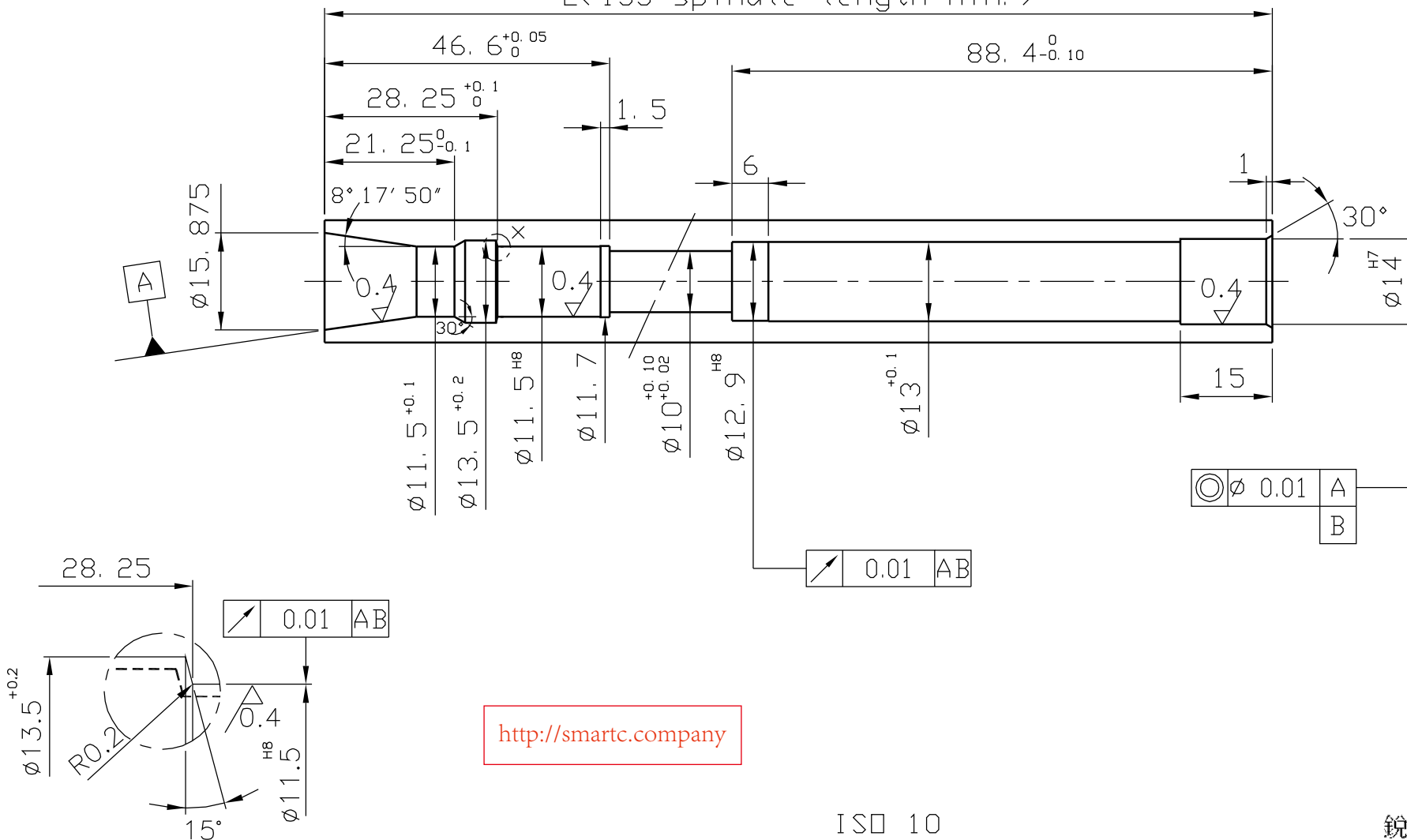

<http://smarc.com>

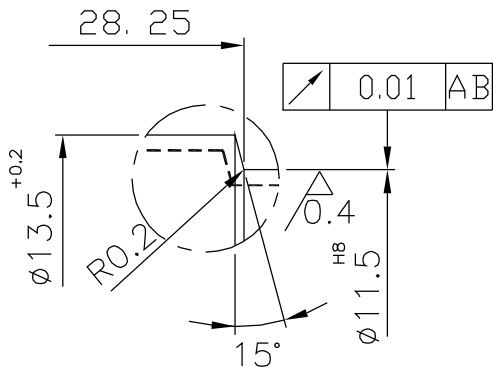

HRc $60 \pm 2^\circ$
Eht. min 1mm

ISO 10

銳角去除

處 理	備 註	材 質	硬 度	第三角法	比 例	台 件	設 計	日 期
	10SPIND1		RC		1/1	1	H. J.	08/06/16
			S.M.	圖 號	10SPINDLE			

10PDBS/100

10PS100

Id. Nr.

Com. Nr.

Opening position H=31.6
Clamping position H=33.6
Free position H=34.6

Opening position 7.6
Clamping position 9.6
Free position 10.6

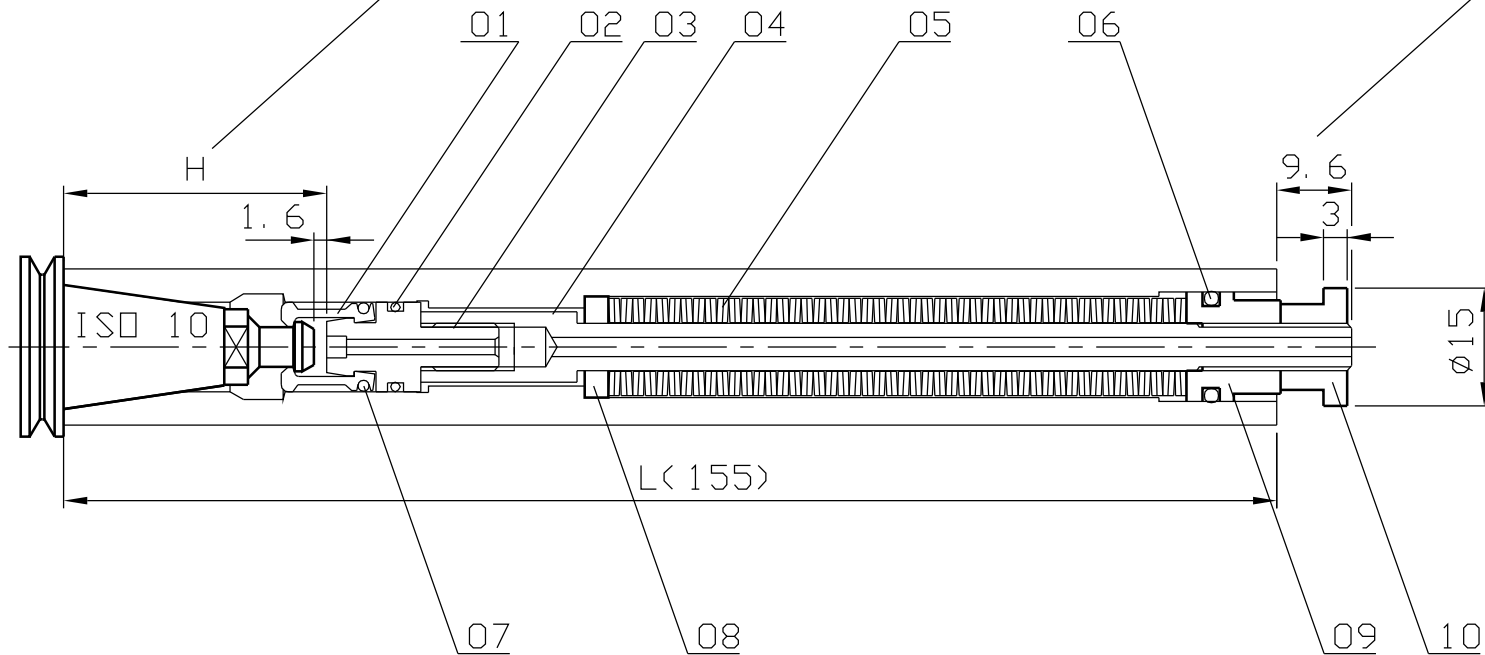

<http://smartc.company>

spring arrangement double
pull-in force 900 N±10%
opening force 1200 N
total clamping stroke 3 mm
ejection stroke 0.4 mm

S.M.

date

08/06/16